

D1 Remote Switch

Flexibility

The D1 remote switch is an easy to use product. Users can easily control the smart lighting device by setting the scene. The controller can be placed on the wall or bedside through its magnetic backplane, or directly on iron materials such as refrigerators and iron cabinets.

Highly customizable

The D1 remote switch direct access to all important Casambi lighting control functions. The preset keys on the D1 remote switch can be configured via the Casambi App. Personalized ICONS can be customized on the keys according to the needs of customers.

Long Range Mode

There are three radio modes: ‘Balanced’, ‘Better Performance’ and now ‘Long Range’ options. Long-range capabilities can reach approx. 120 meters with a good line of sight connection between nodes.



COLOR

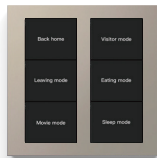

Starlight gold
AL/PC/AG glass

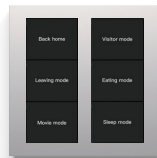

Phantom gray
AL/PC/AG glass

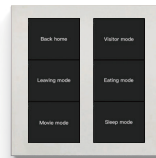

Mica white
AL/PC/AG glass

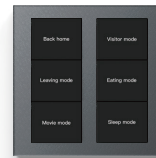

Lava gray
Art glass

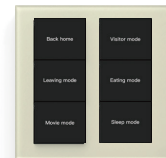

Lava white
Art glass

TECHNICAL PARAMETER

Product size	86 x 86 x 12 mm
Package size	100 x 100 x 60 mm
Weight	0.10kg
Gross weight	0.11 kg
Installation mode	Magnetic/Portabl
Input	3V (2 X CR2032 batteries)
Network mode	Bluetooth Casambi
Material	AL/PC/Glass
Fire rating	94-v0
Working temperature	-10°C~+60°C
Working humidity	≤95%RH, Non-condensing

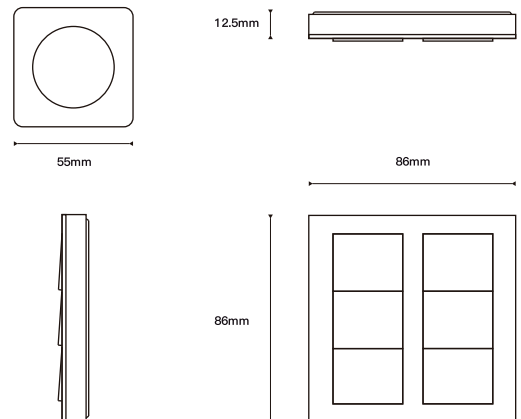

Size Specification

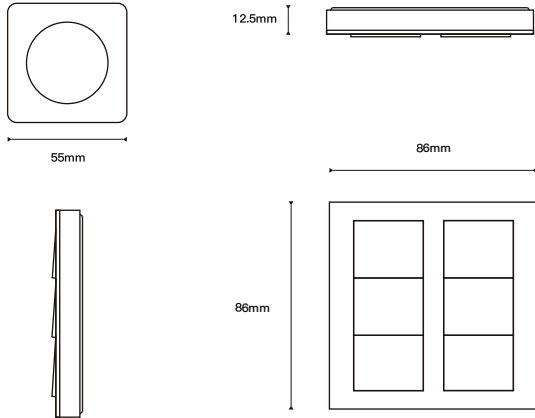

Replace the battery.

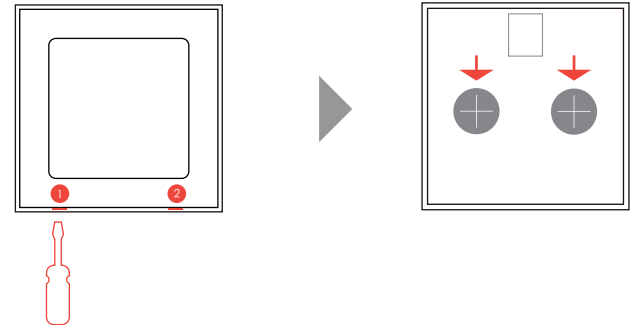

Use a flathead screwdriver to pry open the rear cover at positions 1 and 2 respectively.

Push out the battery in the direction indicated by the arrow, replace it with a new battery, and then reinstall the rear cover.

Button Settings Instruction

Double – click the device to enter the editing page.

Select the button that needs to be edited.

The button can be bound to the following functions.

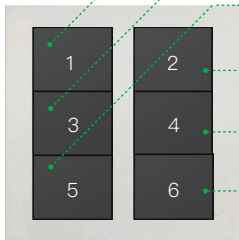
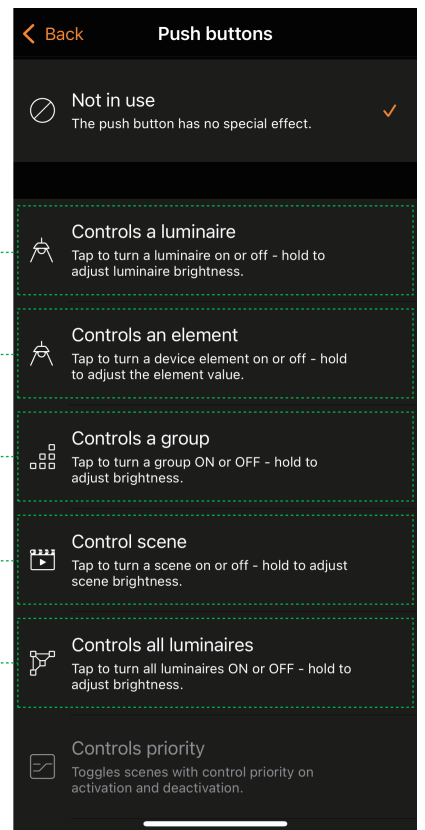
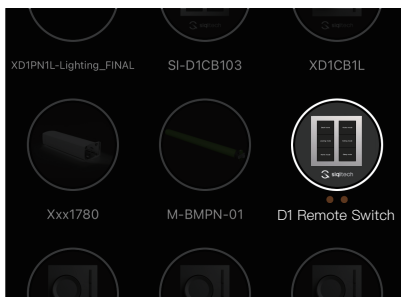

The buttons corresponding to the APP.

Button Capability Setting

The 6 – button remote switch enables the switching between the 6 – button function and the 4 – button plus dimming function through settings.

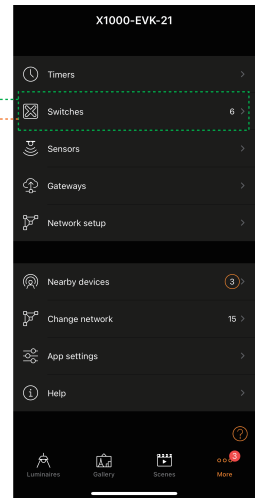

4 buttons + dimming — 6 buttons

6 buttons — 4 buttons + dimming

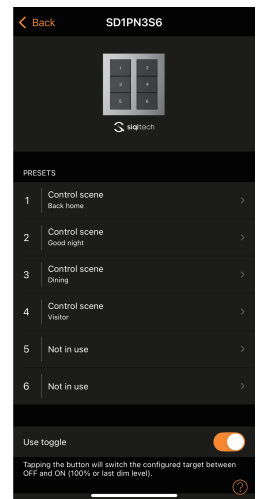
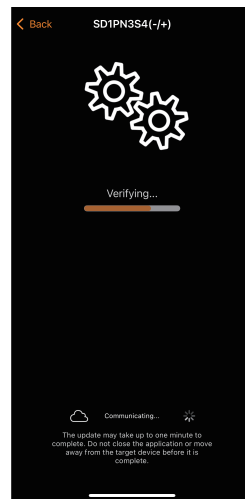
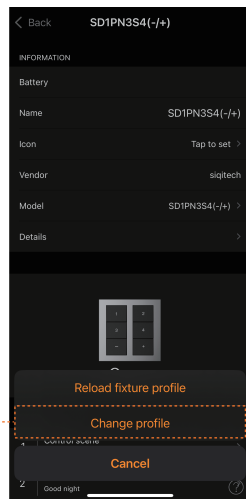
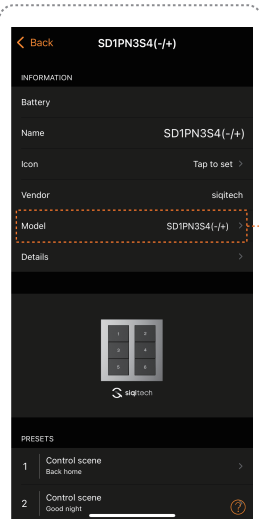
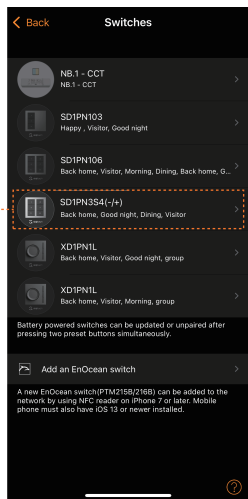

Press and hold any two buttons on the switch simultaneously for more than 1 second to wake up the device and put it into an operable state

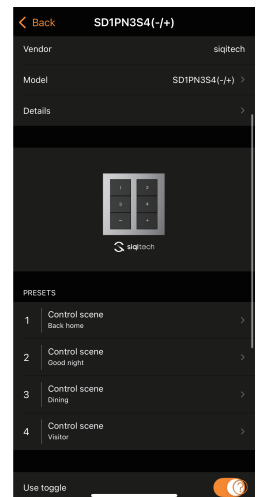
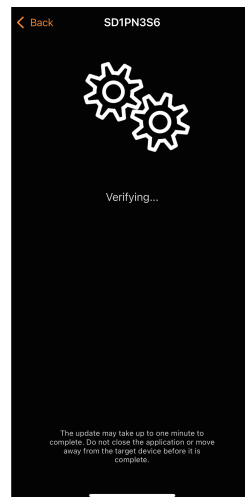
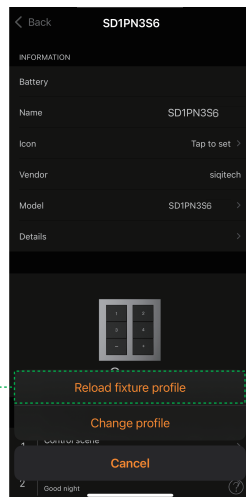
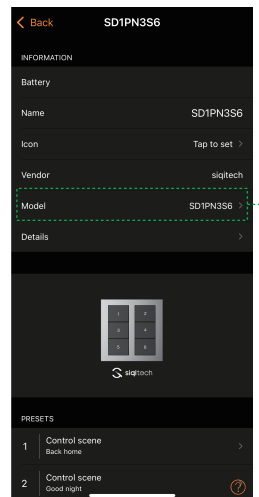
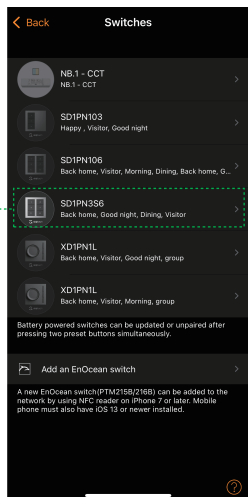

BASIC FUNCTIONS

The preset buttons of D1 Remote Ccontrol can be configured via the Casambi app. A light indicates the selected preset.

Dim up, Dim down:

- Smooth dimming of last chosen preset

Preset buttons:

- Individual luminaire control
- Group control
- Control of all luminaires
- Recall scenes
- Recall animations

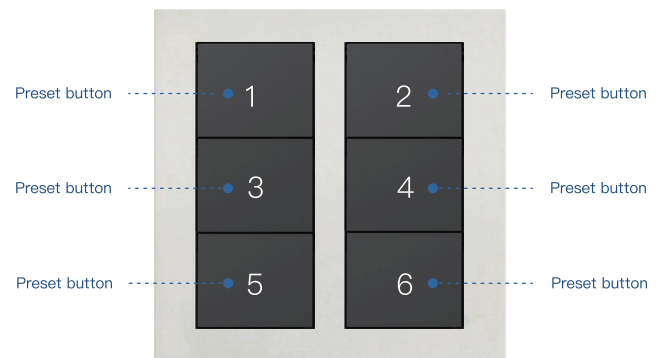

SMART FUNCTIONS

Dimming

- Hold the Dim down or Dim up button:
Smooth dimming of last chosen preset, cycle takes 5 seconds
- Press the Dim down button:
Chosen preset goes to 0%
- Press the Dim up button:
Chosen preset goes to 100%

Preset Buttons

- Press:
The chosen preset (luminaire control, group control, all luminaires, scene recall or animation recall) will turn on
- Press again:
The chosen preset (luminaire control, group control, all luminaires, scene recall or animation recall) will turn off

Turn Off

- Press the Dim down and Dim up button for more than 1 second:
Turns all luminaires off in selected network