

TECHNICAL DATA SHEET

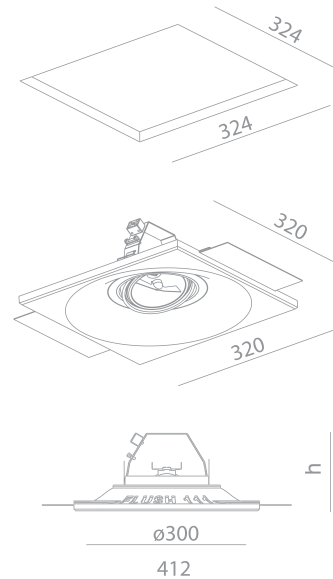

Included: installation system for gypsum ceiling 9 - 12 - 15 mm

OPTIONAL INSTALLATION KIT

REF N° 211 99 025 installation system for gypsum ceiling 25 mm

REF N° 211 99 030 installation system for gypsum ceiling 30 mm

REF N° 811 00 000 Concrete box Flush111 - Galvanized steel

FLUSH 111 AR

REF N° 211 13 100 Adj.

QR-LP 111 - 35-50-75-100W
 G53 - 12V - - excl. transfo
 - - - - 850°C
 h=136 - 324x324 mm

FLUSH 111 CDM

REF N° 211 19 070 Adj. CDM-TC - G8.5

REF N° 211 12 070 Adj. CDM-R - GX8.5

35W or 70W - 230V/50Hz - - excl. EVG
 - - - - 850°C
 h=145 - 324x324 mm

