

TECHNICAL DATA SHEET

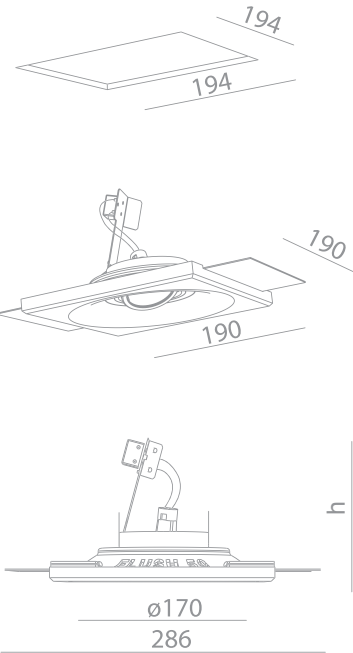

Included: installation system for gypsum ceiling 9 - 12 - 15 mm

OPTIONAL INSTALLATION KIT

REF N° 210 99 025 installation system for gypsum ceiling 25 mm

REF N° 210 99 030 installation system for gypsum ceiling 30 mm

REF N° 810 00 000 Concrete box Flush 50 - Galvanized steel

FLUSH 50 HAL
REF N° 210 10 050 Adj. ⚙ IP20
🔊 QR-CBC 51 - 50W - Gx5.3 - 12V - ⚡ CE excl lamp and transfo - ▽ - ⏏ 0.5m - 850°C 📏 - h=132 - 📏 194x194 mm

FLUSH 50 ES
REF N° 210 11 050 Adj. ⚙ IP20
🔊 QPAR 16 - 50W - GZ10/GU10 - ⚡ CE 230V/50Hz - excl. lamp - ▽ - ⏏ 0.5m - 850°C 📏 - h=132 - 📏 194x194 mm

