

Name: Urban - 90

Design: Joana Bover / 2011

Typology: Pendant lamp







Environment: Indoor

Technical description:

Pendant lamp with frame, finished in brilliant chrome, with a hand wrapped translucent ribbon shade in cream, white, or red. Upper polycarbonate diffuser and lower methacrylate diffuser. Available in four pendant formats.



Lamps description

	Grounding: excluded
	Ready for mounting on normally flammable surface
	6 x 22 W E-27
Voltage: 230V~50Hz	
	1 Box 95 x 95 x 45 cm
Vol.: 0,4061 m <sup>3</sup>	
Weight: 20 kg	
Certifications:  	
	Photometrics made according to the position the lights are shown in the catalogue and price list.

Ref	Finishings
410432506B	Chrome White Translucent Ribbon
410432506C	Chrome Cream Translucent Ribbon
410432506R	Chrome Red Translucent Ribbon
D0432506B	Dali Dimming System Chrome White Translucent Ribbon
D0432506C	Dali Dimming System Chrome Cream Translucent Ribbon
D0432506R	Dali Dimming System Chrome Red Translucent Ribbon

Customizable

Measures

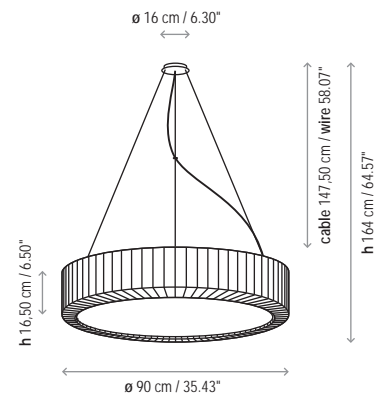

Urban - 37

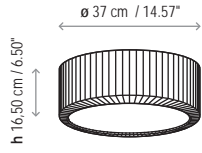

Urban - 60

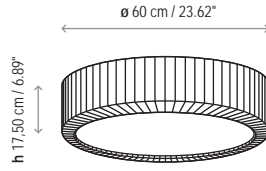

Urban - 90

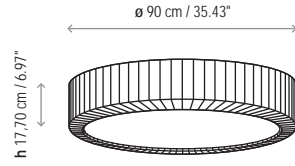

Urban - 120

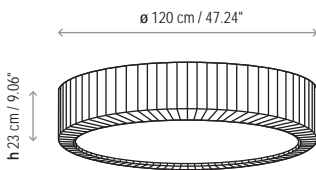

Urban - 37

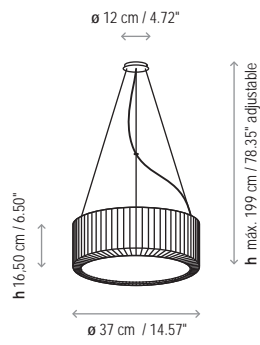

Urban - 60

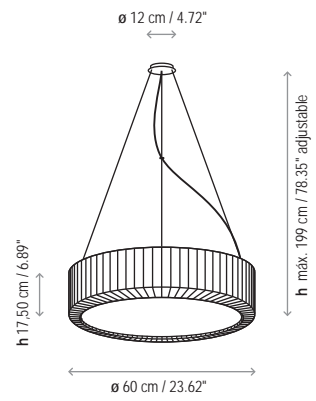

Urban - 90

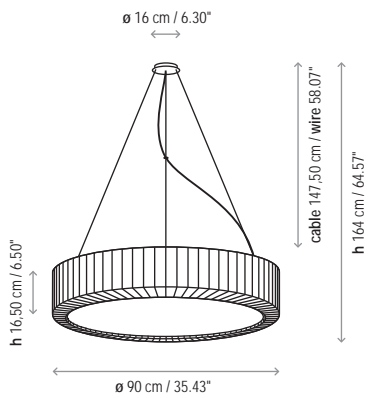

Urban - 120

