

Name: Urban - 37

Design: Joana Bover / 2011

Typology: Pendant lamp

Environment: Indoor

Technical description:

Pendant lamp with frame, finished in brilliant chrome, with a hand wrapped translucent ribbon shade in cream, white, or red. Frosted glass diffuser included with fixture. Available in four pendant formats.



Lamps description

 Grounding: excluded

 Ready for mounting on normally flammable surface

 2 x 46 W Classic P Eco E-27

 2 x 22 W E-27

Voltage: 230V~50Hz

 1 Box 40 x 40 x 25 cm

Vol.: 0,0400 m³

Weight: 5 kg

Certifications:  

 Photometrics made according to the position the lights are shown in the catalogue and price list.

Ref Finishings

410132506B Chrome
White Translucent Ribbon

410132506C Chrome
Cream Translucent Ribbon

410132506R Chrome
Red Translucent Ribbon

Customizable

Measures

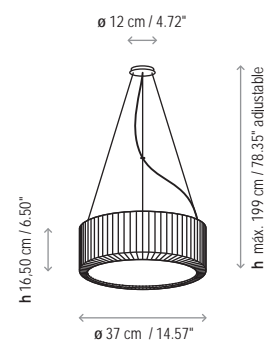

Urban - 37

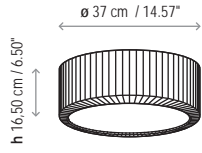

Urban - 60

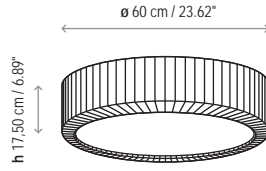

Urban - 90

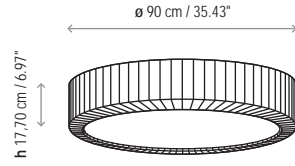

Urban - 120

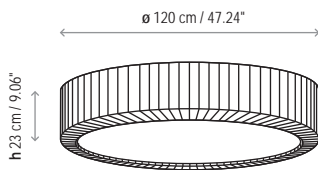

Urban - 37

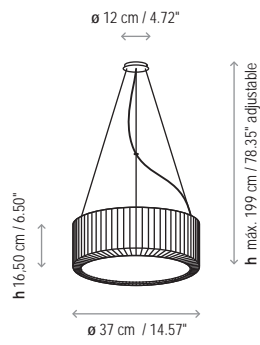

Urban - 60

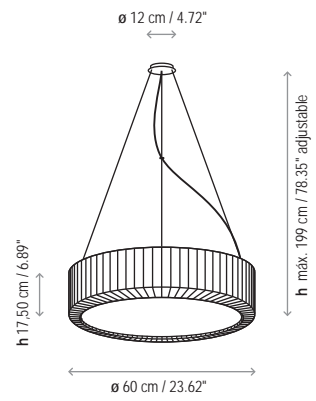

Urban - 90

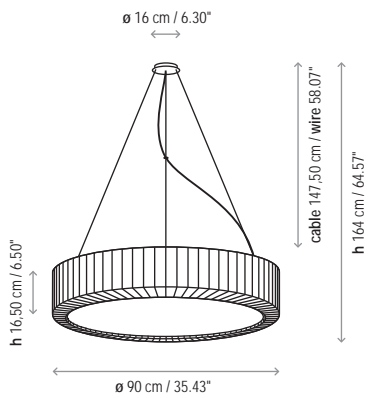

Urban - 120

