

Name: Danona - 3 Luces

Design: Joana Bover / 2002

Typology: Pendant lamp







Environment: Indoor

Technical description:

Pendant lamp with iron structure available in satin nickel, nickel with dark leather trim and nickel with light leather trim finishing. Lampshade available in cotton and white or cream translucent polyester blend hand wrapped ribbon.



Lamps description

	Grounding: compulsory
	Ready for mounting on normally flammable surface
	3 x 77 W Classic A Eco E-27
	3 x 18 W E-27
Voltage: 230V~50Hz	
	1 Box 35 x 45 x 165 cm
Vol.: 0,2599 m ³	
Weight: 6 kg	
Certifications:  	
	Photometrics made according to the position the lights are shown in the catalogue and price list.

Ref Finishings

4323105	Satin Nickel
4323160	Nickel Dark Leather
4323161	Nickel Caramel Leather

Lampshade 27 X 18 X 27 cm

P-150	Cotton
P-005C	Cream Translucent Ribbon
P-006C	White Translucent Ribbon

Extensions have a standard length of 60 cm

Customizable

Measures

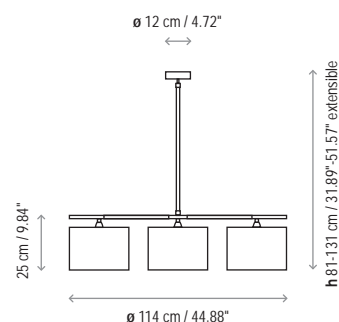

Danona - 1 Luz

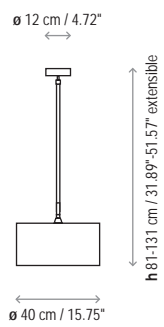

Danona - 3 Luces

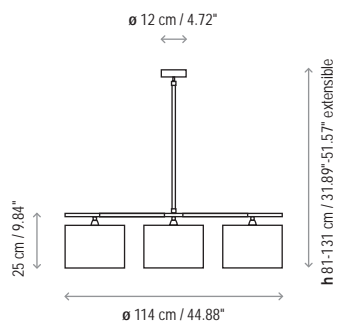

Danona - Mini

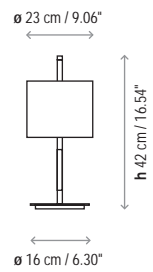

Danona - Mesa

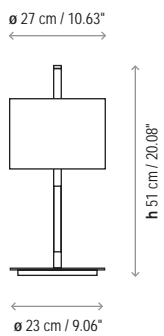

Danona - Pie

