

Step Lite Solid Eyelid PURE LED

Cat. No. SLS/L

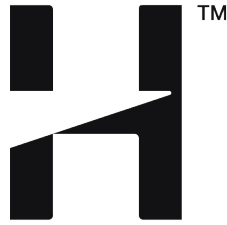
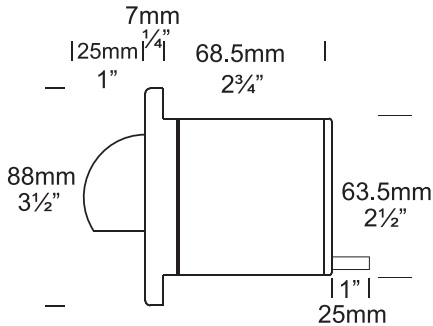

PURE LED
Pure Performance

The Step Lite Solid Eyelid Pure LED has a smooth machined finished without mounting holes to disrupt the elegant line of the fitting and is designed to fit into a mounting canister. The eyelid masks two thirds of the lamp which eliminates all upwards light.

The Hunza PURE LED system uses the latest Cree MTG-2 LED chips for maximum performance and long life. Power supply options include a choice of integral 12 volt driver or an external remote driver. The PURE LED system incorporates an innovative Plug- and-Play system for easy replacement or upgrade of either the LED engine or integral driver. A choice of Warm or Cool White is available.

* At 700mA this fitting is the equivalent of a 35w halogen fitting.

* At 1050mA this fitting is the equivalent of a 50w halogen fitting.

Ordering Information

Luminaire

SLS/S

Driver mA

S - Series
D7 - 12v 700mA
D10 - 12v 1050mA

Colour Temp

2 - 2700K
3 - 3000K
4 - 4000K

Accessories

CJK150 - Cable Joint Kit
STEPF - Frosted Lens
HCL - Hex cell Louvre
SLCAN - Step Lite Canister
CANSS - Step Lite Canister
Stainless Steel
DKCAN - Deck Canister

Material/Finish

BK - Black
BZ - Bronze
GN - Green
STAR - Silver Star
WH - White
WB - Birch
DG - Dark Grey
OG - Olive Green
RG - Beige
PR - Primrose
SS - Stainless Steel
COP - Copper

Ordering Example: SLS/L S 3 HCL BK

HUNZA™ PURE
OUTDOOR
LIGHTING

HUNZA FACTORY
130 Felton Mathew Ave
Saint Johns
Auckland 1072
New Zealand

Ph: 64-9-528 9471
Fax: 64-9-528 9361
hunza@hunza.co.nz
www.hunza.co.nz

INTERNATIONAL CONTACTS:
www.hunza.co.nz/contacts.php

Specifications may change without notice.
Manufactured in New Zealand.
© 2015 Hunza Holdings Ltd.

Luminaire Construction

CNC machined from one of the following metals:

High corrosion resistant 63.5mm (2½") x 10mm (25/64") aluminium. End cap - solid aluminium 63.5mm (2½") rod, flange 90mm (3½") solid aluminium rod with chromate substrate and high UV resistant polyester powder coat
Colours Black, Bronze, Green, Silver Star, White, Birch, Dark Green, Olive Green, Beige, Primrose.

Copper: 63.5mm (2½") x 10mm (13/32"). End cap - solid copper 63.5mm (2½") rod. Flange 90mm (3½") solid copper rod.

316 Stainless Steel: 9mm (11/32"). Enc Cap - solid 316 stainless steel 63.5mm (2½") rod. Flange 90mm (3½") solid 316 stainless steel rod.

Luminaire Weight

Alum .465kg (1lb)
Cop 1.340kg (2lb 15oz)
SS 1.055kg (2lb 5oz)

Luminaire Features

Lens:

3mm (1/8") extra clear low iron flush fit shatter resistant glass. Lifetime Warranty.

Gasket:

Silicone, iron impregnated 220°c (428°f)

Accessories

Cable Joint Kit (Cat. CJK150)
Frosted Lens (Cat. LENSSTEPF)
Hex Cell Louvre (Cat. HCL)
Step Canister (Cat. SLCAN)
316 Stainless Canister for use in lime stone etc. (Cat. CAN)

Mounting

Designed to fit through a 66mm (2 5/8") hole and be fixed into position by two screws in the flange or a Step Lite canister (see accessories) can be used which maintains the aesthetic look of the flange by eliminating the two screw holes in the flange.SS)

Technical Information

Standards

AS/NZS 61046
IP56/IP66 UL 1838

LED

Cree MTG-2 Plug and Play, field replaceable LED board.

Lumen Output: 600 at 1050mA

Lumens Per watt: 100 at 6 watts

CRI Warm White (3000k): 85+

Colour Temp: 2700K, 3000K, and 4000K

Power Supply

Series (External) Driver

Constant current driver
Output: 6vdc at 1050mA maximum

Integral 12 Volt Driver

Hunza™ Plug and Play Driver
Input: 12vac, 7 watt total
Output: 6vdc nominal, 350 / 700 / 1000mA

Transformer

Hunza™ Wall Mount Transformer for use with integral 12 volt driver