



Nolita

Joan Gaspar

marset



Nolita A

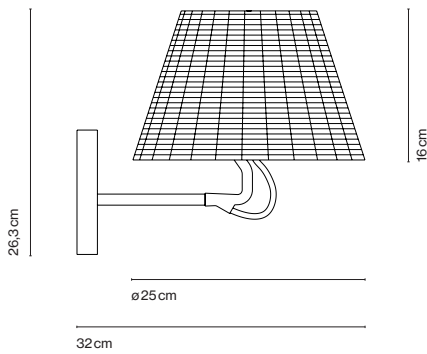

Nolita A

- ⦿ E14 HSGSP/C/UB 46W
- ⦿ E14 LED 5W

Conic diffuser with a double shade made of engraved polycarbonate. Aluminium structure.

Structure

- Aluminium

Difusor

- ⊗ Transparent



[Download](#) Assembly Instructions

[Download](#) 2D

[Download](#) 3D

[Download](#) Energy label

Range

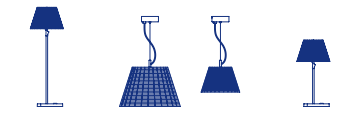

info@marset.com
www.marset.com

Close attention to the overall proportions is the key to the sophistication and elegance of the Nolita collection. Its simplicity of design and structure contrasts with the translucent injected polycarbonate for the shade, combined with the stem in aluminium.