

Lawn Lite

Cat. No. LL
 Cat. No. LL/GU

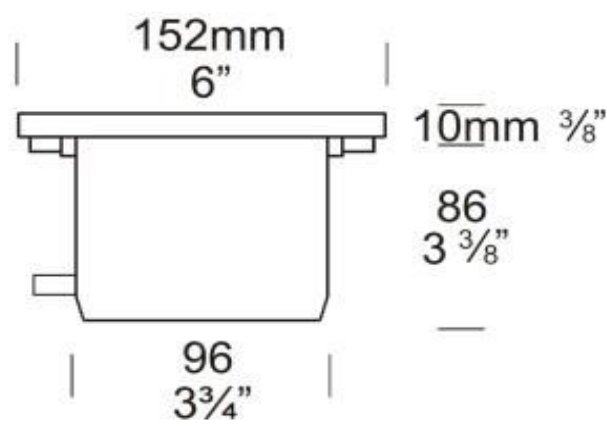

UK & European Specification

The Lawn Lite is designed for insertion into a lawn or garden bed and can be mowed over without damaging the luminaire. Designed so the lamp can be directed up to 20 degrees at a bush tree, or the outside of a building, etc. without the need to remove the luminaire from the ground due to the vandal resistant three stainless steel allen head screw fixing system which attaches the flange to the body of the luminaire. With a 'Flush Fit' lens to stop water pooling and depositing dirt on the lens.

Please note that the GU10 option will drastically reduce the movement of the lamp and an angle of up to 20 degrees will no longer be achievable. Effectively the lamp will be rendered fixed.

Ordering Information

Luminaire	Flange Options	Body	Accessories
LL - Lawn Lite	BK - Black	Luminaires with a Stainless	CJK - Cable joint Kit
LL/GU - GU10	BZ - Bronze	Steel or Bronze flange have	HCR - Hex Cell
	GN - Green	a black body, otherwise body	Retainer
	STAR - Silver Star	is the same as flange colour.	LENSLLF - Frosted
	SBZ - Solid Bronze		Lens
	SS - 316 Stainless Steel		

Example: **LL BK**

(Accessories ordered separately)

Luminaire Construction

Body:

Cast from virgin high corrosion resistant CC401 low copper aluminium alloy, with chromate substrate and high UV resistant polyester powder coat

Colours Black, Bronze, Green, Silver Star, White, Birch, Dark Green, Olive Green, Beige, Primrose.

Flanges:

The flange is attached to the body by three 316 stainless steel allen head anti vandal screws and is available in either powder coated solid aluminium or CNC machined from one of the following metals:
Solid Bronze - 150mm (6") bar.
Solid 316 Stainless Steel - 150mm (6") rod.

Mounting

Suitable for insertion into a lawn or gardens etc. mounted level with ground surface, seated on its base.

Features

Lens:

12mm (1/2") 'Flush Fit' clear tempered shatter resistant glass.
Lifetime Warranty.

Gaskets:

Nytral 220°C (428°F)

Lamp Holder:

GU5.3 & GU10 - 350°C (662°F) ceramic multi contact lamp holder with 250°C (480°F) teflon cables.
Lamp holder can be rotated 360° and angled up to 20°.

Accessories:

Cable Joint Kit (Cat. CJK150).
Frosted Lens (Cat. LENSLLF).
Hex Cell Retainer (Cat. HCR).
GU10 Option (Cat. GU).

Standards

IP67
UL1838

Luminaire Weight

ALUM .94kg (2lb 1oz)
SOLID BRZ 1.14kg (2lb 8oz)
SS 1.13kg (2lb 7oz)

Power Supply

HUNZA™ Inground or HUNZA™ Wall Mount Transformer: not included.

Supplied With

MR16 GU5.3 20 or 35 watt lamp max.
GU10 - GU10 25 or 35 watt lamp max.

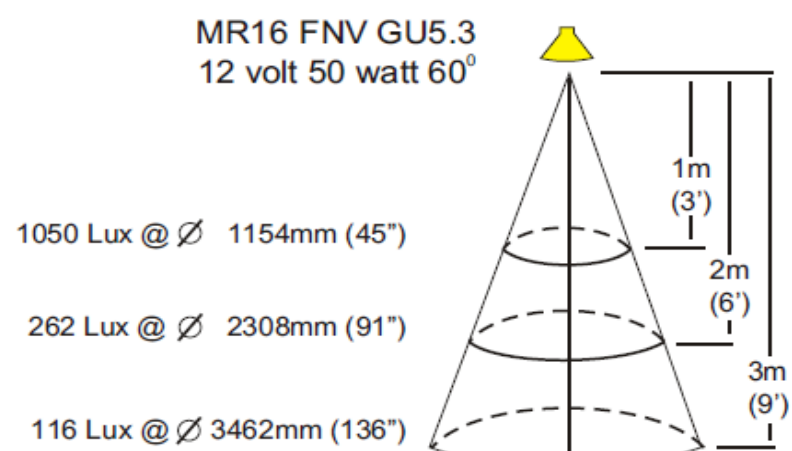
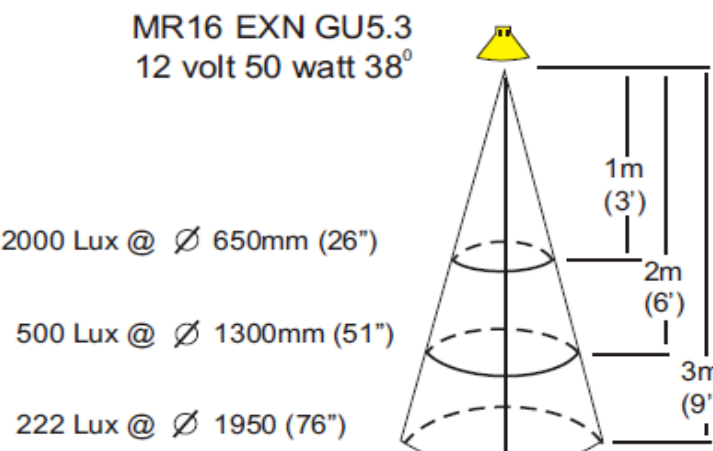
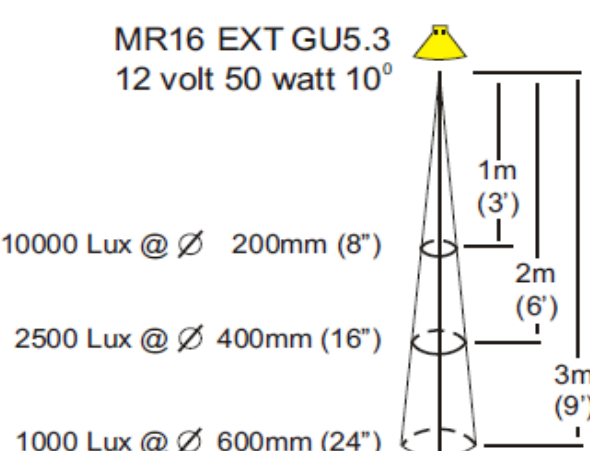
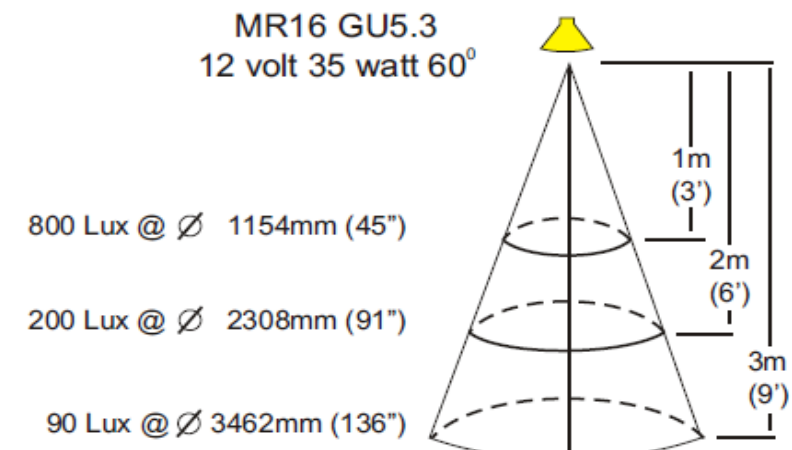
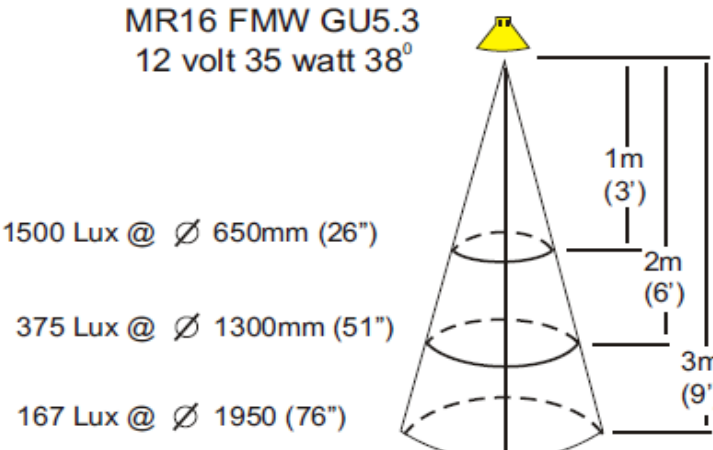
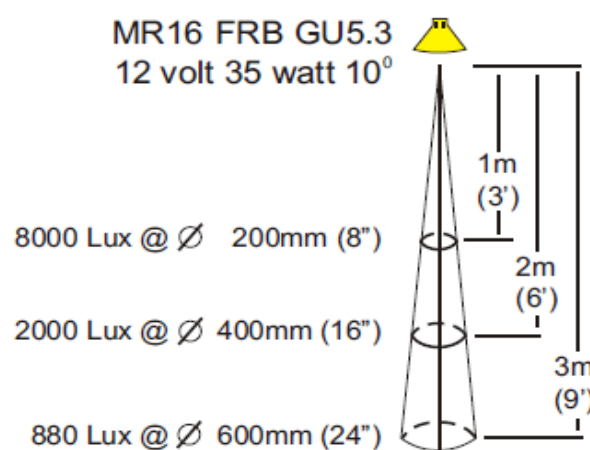
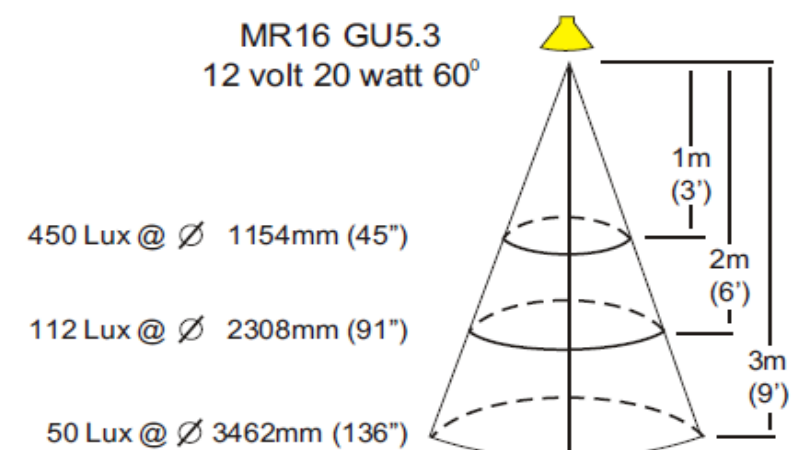
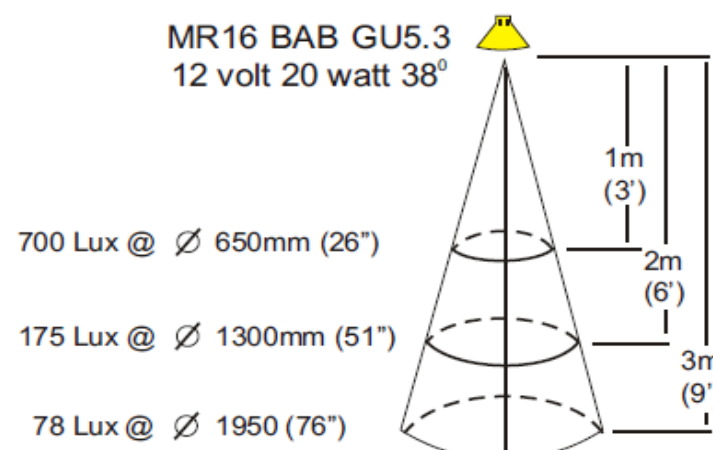
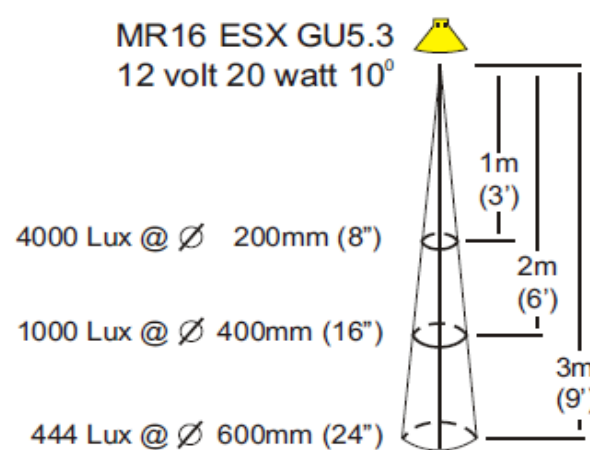

	<p>HUNZA FACTORY 130 Felton Mathew Ave Saint Johns Auckland 1072 New Zealand</p>	<p>Ph: 64-9-528 9471 Fax: 64-9-528 9361 hunza@hunza.co.nz www.hunza.co.nz</p>	<p>INTERNATIONAL CONTACTS: www.hunza.co.nz/contacts.php Specifications may change without notice. Manufactured in New Zealand. © 2014 Hunza Holdings Ltd.</p>
--	--------------------------------------------------------------------------------------------------	-------------------------------------------------------------------------------------------	------------------------------------------------------------------------------------------------------------------------------------------------------------------------------------