

Euro Step Lite Solid Eyelid

Cat. No. ESLS



The Euro Step Lite Solid Eyelid is an extra compact luminaire designed for step lighting applications where the fixture needs to be very unobtrusive or concealed. The eyelid masks two thirds of the lamp, which eliminates all upward light.

Hunza Euro fixtures use miniature MR11 lamps to achieve a contemporary, discreet appearance but are still able to provide excellent illumination. The Euro Step Lite is designed for recessed mounting into masonry, stone or wood and when the appropriate Hunza mounting canister is specified there are no visible mounting screws.

Ordering Information

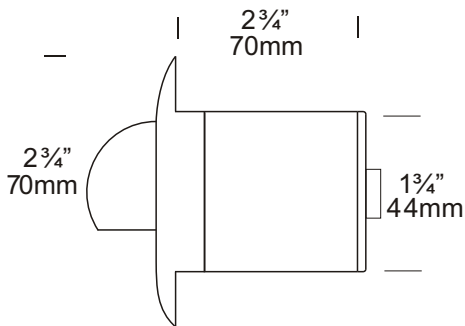

Luminaire Type

ESLS - Euro Solid Eyelid
Step Lite

Material

COP - Copper
SS - 316 Stainless Steel

Accessories

CJK150 - Cable Joint Kit
Elcan - Euro Lite Canister
LENSEURF - Frost Lens
EDKCAN - Euro Lite Deck
Canister

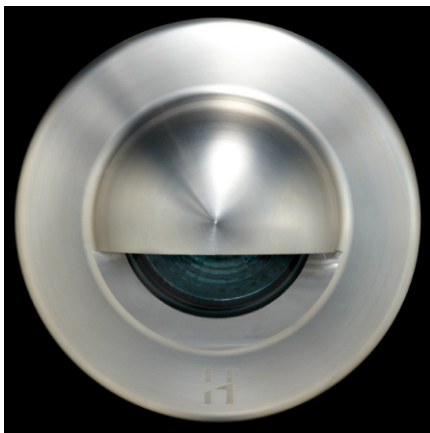

Ordering Example: ESLS COP - Euro Step Lite Solid Eyelid in
Copper.
(Accessories ordered separately)

HUNZA™ PURE
OUTDOOR
LIGHTING

HUNZA FACTORY
130 Felton Mathew Ave
Glen Innes
Auckland 1072
New Zealand

Ph: 64-9-528 9471
Fax: 64-9-528 9361
hunza@hunza.co.nz
www.hunza.co.nz

INTERNATIONAL CONTACTS:
www.hunza.co.nz/contacts.php

Specifications may change without notice.
Manufactured in New Zealand.
© 2011 Hunza Holdings Ltd.

Ver 1.4

Luminaire Construction

CNC machined from:

Body:

45mm (1¾") copper rod.

Flange:

70mm (3½") solid copper rod.

Body:

45mm (1¾") 316 stainless steel rod.

Flange:

70mm (3½") solid 316 stainless steel rod.

Mounting

The Euro Solid Eyelid Step Lite is fixed in place using a mounting canister. There are no mounting screws in the flange to spoil aesthetics of the luminaire.

Features

Lens:

6mm (¼") clear flush fit shatter resistant glass with Hex Cell Louvre for glare control.

Lifetime Warranty.

Gaskets:

Silicone, iron impregnated 220°C (428°F).

Lamp Holder:

GU4 - 350°C (662°F) ceramic multi contact lamp holder with 250°C (480°F) teflon cables.

Accessories:

Cable Joint Kit (Cat. CJK150)

Not approved for USA/Canada.

Euro lite Canister (Cat. Elcan).

Frosted Lens (Cat. LENSEURF).

Euro Lite Deck Canister (EDKCAN)

Standards

IP66



UL1838

Luminaire Weight

Cop .635kg (1lb 6oz)

SS .585kg (1lb 4oz)

Power Supply

HUNZA™ Inground or Wall Mount Transformer: not included.

USA and Canada:

HUNZA™ Wall Mount Transformer: not included.

Lamp Type

MR11 GU4 20 watt lamp max.

LED - Refer to previous page.

USA and Canada:

MR11 GU4 10 watt lamp max.

LED - Refer to previous page.

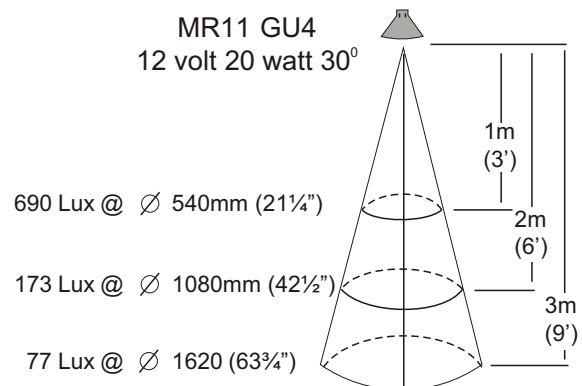
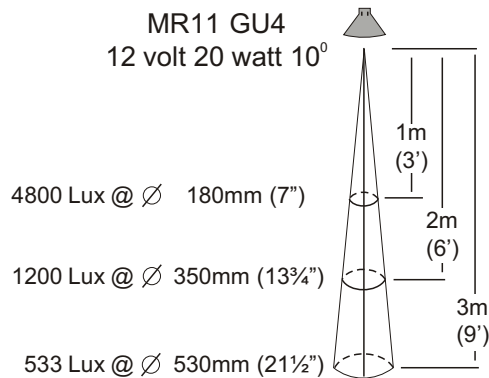

HUNZA™ PURE
OUTDOOR
LIGHTING

HUNZA FACTORY
130 Felton Mathew Ave
Glen Innes
Auckland 1072
New Zealand

Ph: 64-9-528 9471
Fax: 64-9-528 9361
hunza@hunza.co.nz
www.hunza.co.nz

INTERNATIONAL CONTACTS:
www.hunza.co.nz/contacts.php

Specifications may change without notice.
Manufactured in New Zealand.
© 2011 Hunza Holdings Ltd.

Ver 1.4