

E-Lite

Cat. No. EAVE
 Cat. No. EAVE105
 Cat. No. EAVEGU
 Cat. No. EAVE105GU



The E-Lite is a recessed downlight ideal for installation in eaves, soffits, entrance ways, verandahs, carports or covered decks. It can also be used in bathrooms, kitchens or where moisture transfer or decibel rating is a minimum requirement.

This luminaire is machined from a choice of solid aluminium with a UV stable powder coated finish, solid copper or 316 stainless steel with a clear, tempered, flush glass lens and high temperature silicon gaskets. The 316 stainless steel E-Lite is electro-polished to increase corrosion protection.

A 105mm version of the E-Lite is available and has been designed to fit a standard 90mm cut-out with an enlarged canister lip.

A GU10 version of this luminaire is also available for line voltage lamps.

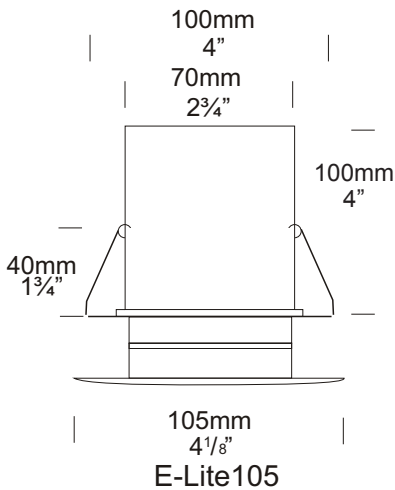
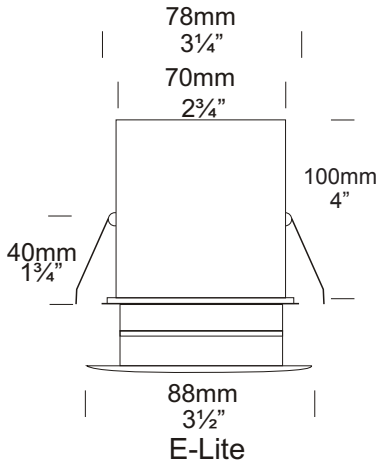

E-Lite

Ordering Information

Luminaire Type	Material	Accessories
EAVE - E-Lite	BK - Black	LENSSTEPF - Frost Lens
EAVE105 - E-Lite 105mm	BZ - Bronze	GU - GU10 Option
	GN - Green	
	STAR - Silver Star	
	WH - White	
	WB - Birch	
	DG - Dark Grey	
	OG - Olive Green	
	RG - Beige	
	PR - Primrose	
	SS - 316 Stainless Steel	
	COP - Copper	

Ordering Example: EAVE COP - E-Lite in Copper

EAVE105 BK - E-Lite in Black with 105mm flange

EAVEGU COP - E-Lite GU10 in Copper

HUNZA™ PURE OUTDOOR LIGHTING

HUNZA FACTORY
 130 Felton Mathew Ave
 Glen Innes
 Auckland 1072
 New Zealand

Ph: 64-9-528 9471
 Fax: 64-9-528 9361
hunza@hunza.co.nz
www.hunza.co.nz

INTERNATIONAL CONTACTS:
www.hunza.co.nz/contacts.php

Specifications may change without notice.
 Manufactured in New Zealand.
 © 2011 Hunza Holdings Ltd.

Ver 1.4

Luminaire Construction

CNC machined from:

Aluminium body high corrosion resistant 88mm (3½"), or 105mm (4¼") solid aluminium rod with chromate substrate and high UV resistant polyester powder coat.

Colours Black, Bronze, Green, Silver Star, White, Birch, Dark Green, Olive Green, Beige, Primrose.

Copper body 88mm (3½"), or 105mm (4¼").

316 Stainless Steel body 88mm (3½"), or 105mm (4¼"). Electro-polished.

Canister 316 Stainless Steel
Mounting

The canister supplied is designed to fit through a 70mm hole and be fixed into position by two spring clips. The E-Lite105 canister has a larger flange (105mm) and has been designed to fill a 90mm hole.

Features

Lens:

10mm (3/8") clear flush fit shatter resistant glass. A clear lens is fitted as standard.

Lifetime Warranty.

Lamp Holders:

GU5.3 & GU10 - 350°C (662°F) ceramic multi contact lamp holder with 250°C (480°F) teflon cables.

Accessories:

Frost Lens (Cat. LENSSTEPF). GU10 Option (Cat. GU10).

The stainless steel E-Lite is electro-polished, this finish increases the protection against corrosion by up to 33%.

Standards

IPX5

NZIEP 54 = CA, SCB 100mm
HBX 75mm, REC 135mm
DB = RW30

Weight

E-Lite Alum .30 kg (11oz)
Cop .80 kg (1lb 12oz)
SS .75 kg (1lb 10oz)

E-Lite105 Alum .40 kg (14oz)
Cop .95 kg (2lb 2oz)
SS .90 kg (2lb)

Power Supply

HUNZA™ H20, H40 or H50
Transformer: not included.

Lamp Type

Suitable for use with Halogen
MR16 GU5.3 50 watt lamp max.
GU10 - GU10 25 or 35 watt lamp max.

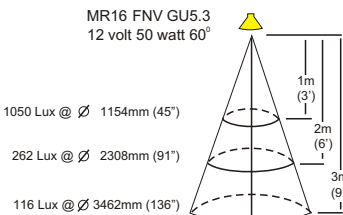
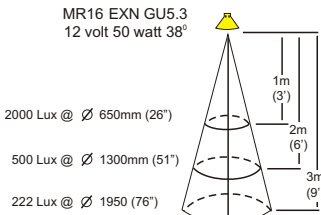
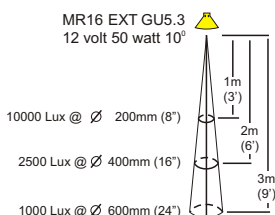
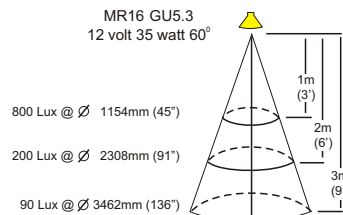
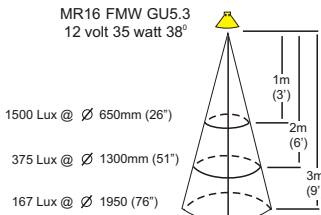
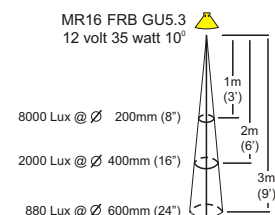
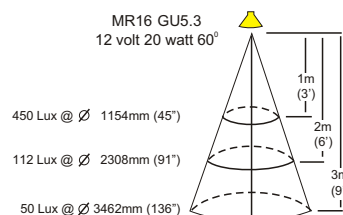
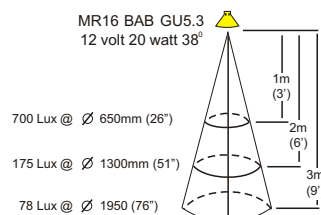
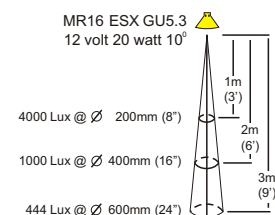

HUNZA™ PURE
OUTDOOR
LIGHTING

HUNZA FACTORY
130 Felton Mathew Ave
Glen Innes
Auckland 1072
New Zealand

Ph: 64-9-528 9471
Fax: 64-9-528 9361
hunza@hunza.co.nz
www.hunza.co.nz

INTERNATIONAL CONTACTS:
www.hunza.co.nz/contacts.php

Specifications may change without notice.
Manufactured in New Zealand.
© 2011 Hunza Holdings Ltd.

Ver 1.4