

## TRACK RECESSED CEILING SYSTEM

DLD  
CONTRACT

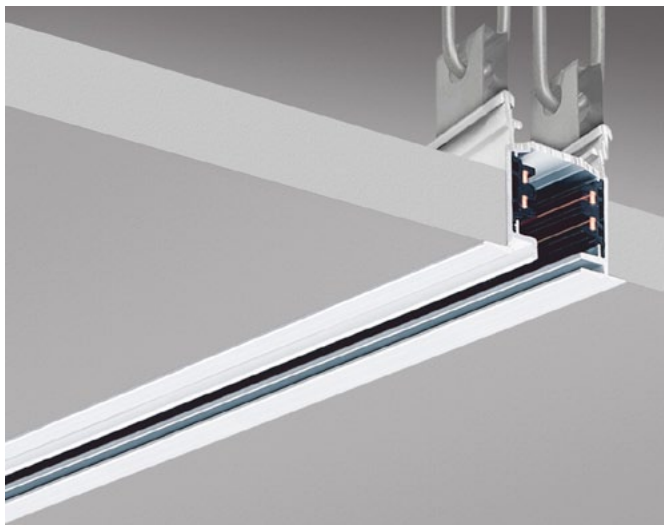

**Dimensions**  
W.59mm H.41mm



### OVERVIEW

- Modular recessed ceiling track system
- Available in 3 lengths: 2m, 3m & 4m
- 40mm cutout
- Compatible with global track luminaires
- Aluminium finished in white
- Multiple connectors available

# TRACK RECESSED CEILING SYSTEM



## DIAGRAMS

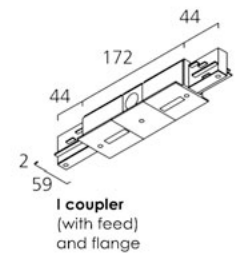
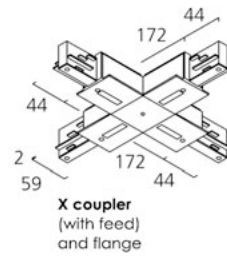
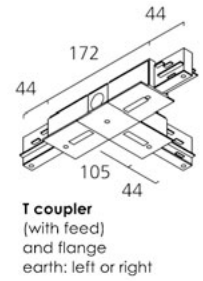
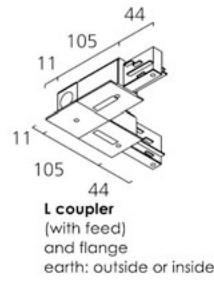
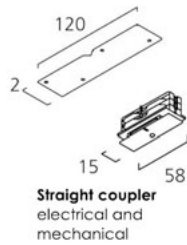
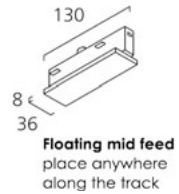
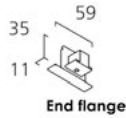
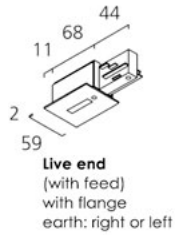
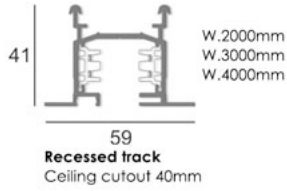

All the information in this document is provided in good faith. DLD Contract will not be held responsible for any losses due to inaccuracies within this document.

01189 889414

[enquiries@dld-contract.co.uk](mailto:enquiries@dld-contract.co.uk)

[dld-contract.co.uk](http://dld-contract.co.uk)

DLD Contract Ltd  
Unit 9 Brookside Business Centre  
Church Road  
Swallowfield  
Reading  
Berkshire  
RG7 1TH