

# DARKLIGHT DESIGN

## DARKLIGHT DESIGN

100W CONSTANT VOLTAGE LINEAR LED TAPE  
TRIAC DIMMABLE DRIVER

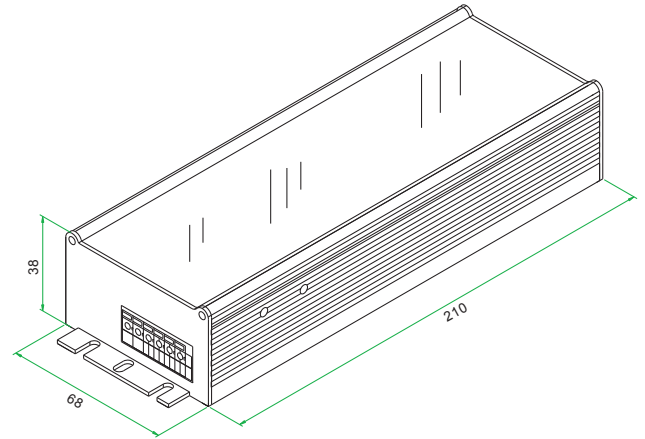

### PRODUCT OVERVIEW

- Linear LED TRIAC dimmable driver
- Suitable for most leading/trailing edge dimming
- Selectable constant voltage output
- Fully-isolated, delivering up to 100W of power
- Short circuit, over current and over voltage protection
- Built-in PFC function (PFC>0.95)
- Cooling by free air convection
- Up to 80% efficient
- Fireproof environmental protection PC plastic cover
- 2 years quality warranty

All the information in this document is provided in good faith. Darklight Design will not be held responsible for any losses due to inaccuracies within this document.

# DARKLIGHT DESIGN

## DARKLIGHT DESIGN

100W CONSTANT VOLTAGE LINEAR LED TAPE  
TRIAC DIMMABLE DRIVER

### TECHNICAL SPECIFICATIONS

<b>Input Voltage Range</b>	90-130V & 180-240V/AC		
<b>AC Frequency</b>	48-62Hz		
<b>Input current</b>	1.5Amax		
<b>Output Mode</b>	Constant Voltage		
<b>Output Current</b>	7000mA	4200mA	2100mA
<b>On Load Voltage</b>	±2V	24V	48V
<b>No Load Voltage</b>	±2V	24V	48V
<b>Output Power</b>	100W Max.		
<b>Power Factor</b>	>0.95		
<b>Efficiency</b>	>80%		
<b>Dimensions</b>	W:210 x D:68 x H:38(mm)		
<b>Weight</b>	550g		

All the information in this document is provided in good faith. Darklight Design will not be held responsible for any losses due to inaccuracies within this document.

# DARKLIGHT DESIGN

## DARKLIGHT DESIGN

100W CONSTANT VOLTAGE LINEAR LED TAPE

TRIAC DIMMABLE DRIVER

### ENVIRONMENTAL SPECIFICATIONS

<b>Operating Temperature</b>	-30~45°C
<b>Storage Temperature</b>	-40~+70°C
<b>Thermal Dissipation</b>	Nature
<b>Relative Humidity</b>	5~95%
<b>Isolation Voltage</b>	In/Out 3000VAC
<b>Vibration</b>	5-55Hz/2g, 30 Minutes
<b>Life Time</b>	50000 Hours, at TC max

### CONFORMITY & STANDARDS

<b>EMI</b>	EN55022 EN55015 Class B
<b>Safety</b>	EN60598
<b>Electromagnetic Immunity</b>	EN61547, ENV5024 EN61000-4-2/3/4/6/8/11
<b>Harmonic Current Emissions</b>	EN61000-3-2 EN61000-3-3

All the information in this document is provided in good faith. Darklight Design will not be held responsible for any losses due to inaccuracies within this document.

# DARKLIGHT DESIGN

## DARKLIGHT DESIGN

100W CONSTANT VOLTAGE LINEAR LED TAPE

TRIAC DIMMABLE DRIVER

### BASIC INSTALLATION OVERVIEW



All the information in this document is provided in good faith. Darklight Design will not be held responsible for any losses due to inaccuracies within this document.