

# TECHNICAL DATA SHEET

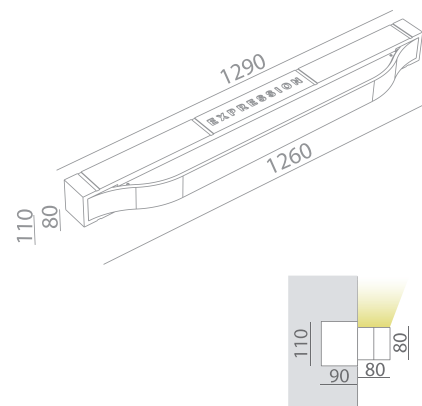

## EXPRESSION DUO FLUO

REF N° 319 15 021 on/off  
REF N° 319 18 021 DIM 1-10V  
REF N° 319 30 021 DIM DALI

1 × T16 - 21/39W  
G5 - 230V/50Hz - <math>\triangle</math> - incl. EVG  
<math>\nabla</math> - <math>\downarrow</math>0.5m - <math>\text{E}</math> - <math>\text{CE}</math> - IP20 - 850°C  
<math>\text{P}</math> - <math>\text{eco}</math>

## EXPRESSION DUO LED 3000 LM

REF N° 319 25 000 on/off 2700°K  
REF N° 319 25 100 on/off 3000°K  
REF N° 319 65 000 DIM 1-10V 2700°K  
REF N° 319 65 100 DIM 1-10V 3000°K  
REF N° 319 35 000 DIM DALI 2700°K  
REF N° 319 35 100 DIM DALI 3000°K

230V/50Hz - 28,5W - 3000lm@65°C -  
3300lm@25°C - <math>\text{E}</math> - <math>\text{CE}</math> - IP20 - CRI 80  
parallel wiring <math>\nabla</math> - <math>\downarrow</math>0.2m - 850°C <math>\text{P}</math> <math>\square</math>  
Integrated line voltage LED driver  
Connects directly to 230 VAC  
4 SDCM - 4 Step MacAdam

Ready for installation in solid walls  
Optional plasterkit for installation into gypsum walls

### PLASTERKIT EXPRESSION

REF N° 718 01 000 For mounting into gypsum walls  
<math>\text{P}</math> 115x1295 mm. Housing: perforated aluminium

