

# TECHNICAL DATA SHEET

## TOUCH-IT 50 LED 700LM CRI 80

REF N° 234 72 040 Adj. ⚡ phase DIM 2700K  
 REF N° 234 72 140 Adj. ⚡ phase DIM 3000K  
 REF N° 234 72 142 Adj. ⚡ phase DIM Vibrant V830  
 REF N° 234 72 240 Adj. ⚡ phase DIM 4000K  
 REF N° 234 62 040 Adj. ⚡ DIM 1-10V 2700K  
 REF N° 234 62 140 Adj. ⚡ DIM 1-10V 3000K  
 REF N° 234 62 142 Adj. ⚡ DIM 1-10V Vibrant V830  
 REF N° 234 62 240 Adj. ⚡ DIM 1-10V 4000K

Xicato LED - 8,3 W - 720lm @ 70°C  
 ☐ - 230V/50Hz - incl LED driver - IP20  
 36° - ▽ - (0.5m) - ⚡ CE - 850°C - 2 SDCM  
 h=115 - (250x250 mm)

## TOUCH-IT 50 LED 500LM CRI 97

REF N° 234 72 940 Adj. ⚡ phase DIM 2700K  
 REF N° 234 72 840 Adj. ⚡ phase DIM 3000K  
 REF N° 234 72 842 Adj. ⚡ phase DIM Vibrant V930  
 REF N° 234 72 740 Adj. ⚡ phase DIM 4000K  
 REF N° 234 62 940 Adj. ⚡ DIM 1-10V 2700K  
 REF N° 234 62 840 Adj. ⚡ DIM 1-10V 3000K  
 REF N° 234 62 842 Adj. ⚡ DIM 1-10V Vibrant V930  
 REF N° 234 62 740 Adj. ⚡ DIM 1-10V 4000K

Xicato LED - 8,5 W - 500lm @ 70°C  
 ☐ - 230V/50Hz - inclusive LED driver  
 36° - ▽ - (0.5m) - ⚡ CE - 850°C - 2 SDCM  
 h=115 - (250x250 mm)

## TOUCH-IT 50 LED 700LM CRI 80 FIX IP54

REF N° 234 72 041 BATHROOM phase DIM 2700K  
 REF N° 234 72 141 BATHROOM phase DIM 3000K  
 REF N° 234 72 045 OUTDOOR phase DIM 2700K  
 REF N° 234 72 145 OUTDOOR phase DIM 3000K

Xicato LED - 8,3 W - 720lm @ 70°C  
 ☐ - 230V/50Hz - inclusive LED driver  
 36° - ▽ - (0.5m) - ⚡ CE - 850°C - 2 SDCM  
 Outdoor: Waterproof Calcyt+®  
 h=115 - (250x250 mm)

## TOUCH-IT 50 LED 500LM CRI 97 FIX IP54

REF N° 234 72 941 BATHROOM phase DIM 2700K  
 REF N° 234 72 841 BATHROOM phase DIM 3000K  
 REF N° 234 72 945 OUTDOOR phase DIM 2700K  
 REF N° 234 72 845 OUTDOOR phase DIM 3000K

Xicato LED - 8,5 W - 500lm @ 70°C  
 ☐ - 230V/50Hz - inclusive LED driver  
 36° - ▽ - (0.5m) - ⚡ CE - 850°C - 2 SDCM  
 Outdoor: Waterproof Calcyt+®  
 h=115 - (250x250 mm)

## TOUCH-IT 50 HAL

REF N° 234 10 050 Adj. ⚡ IP20  
 REF N° 234 10 051 Fix. IP54 BATHROOM  
 REF N° 234 10 055 Fix. IP54 OUTDOOR

⚡ QR-CBC 51 - 50W - Gx5.3 - 12V - ⚡ CE  
 excl lamp and transfo - ▽ - (0.5m) - 850°C  
 Outdoor: Waterproof Calcyt+®  
 ⚡ - h=92 - (250x250 mm)

## TOUCH-IT 50 ES

REF N° 234 11 050 Adj. ⚡ IP20  
 REF N° 234 11 051 Fix. IP54 BATHROOM  
 REF N° 234 11 055 Fix. IP54 OUTDOOR

⚡ QPAR 16 - 50W - GZ10/GU10 - ⚡ CE  
 230V/50Hz - excl. lamp - ▽ - (0.5m) - 850°C  
 Outdoor: Waterproof Calcyt+®  
 ⚡ - h=93 - (250x250 mm)

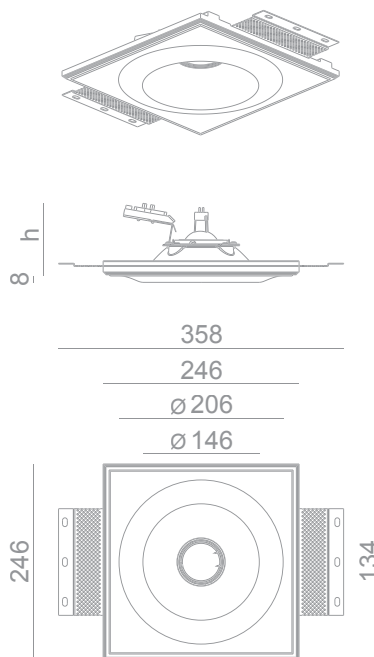

Included: installation system for gypsum ceiling 9 - 12 - 15 mm

### OPTIONAL INSTALLATION KIT

REF N° 234 99 025 installation system for gypsum ceiling 25 mm  
 REF N° 234 99 030 installation system for gypsum ceiling 30 mm  
 REF N° 200 50 000 clip on lampholder ring, without diffuser  
 REF N° 200 50 001 clip on lampholder ring - with frosted diffuser  
 REF N° 834 00 000 Concrete box Touch-it 50 - Galvanized steel

