

TECHNICAL DATA SHEET

INDOX 2X50 LED 700LM CRI 80

REF N° 229 72 040 Adj. ⚡ phase DIM 2700K
 REF N° 229 72 140 Adj. ⚡ phase DIM 3000K
 REF N° 229 72 142 Adj. ⚡ phase DIM Vibrant V830
 REF N° 229 72 240 Adj. ⚡ phase DIM 4000K
 REF N° 229 62 040 Adj. ⚡ DIM 1-10V 2700K
 REF N° 229 62 140 Adj. ⚡ DIM 1-10V 3000K
 REF N° 229 62 142 Adj. ⚡ DIM 1-10V Vibrant V830
 REF N° 229 62 240 Adj. ⚡ DIM 1-10V 4000K

2xXicato LED - 2x8,3 W - 2x720lm @ 70°C
 ☐ - 230V/50Hz - incl LED driver - IP20
 36° - ▽ - (0.5m) - ⚡ CE - 850°C - 2 SDCM
 h=122 - (144x283 mm)

INDOX 2X50 LED 500LM CRI 97

REF N° 229 72 940 Adj. ⚡ phase DIM 2700K
 REF N° 229 72 840 Adj. ⚡ phase DIM 3000K
 REF N° 229 72 842 Adj. ⚡ phase DIM Vibrant V930
 REF N° 229 72 740 Adj. ⚡ phase DIM 4000K
 REF N° 229 62 940 Adj. ⚡ DIM 1-10V 2700K
 REF N° 229 62 840 Adj. ⚡ DIM 1-10V 3000K
 REF N° 229 62 842 Adj. ⚡ DIM 1-10V Vibrant V930
 REF N° 229 62 740 Adj. ⚡ DIM 1-10V 4000K

2xXicato LED - 2x8,5 W - 2x500lm @ 70°C
 ☐ - 230V/50Hz - inclusive LED driver
 36° - ▽ - (0.5m) - ⚡ CE - 850°C - 2 SDCM
 h=122 - (144x283 mm)

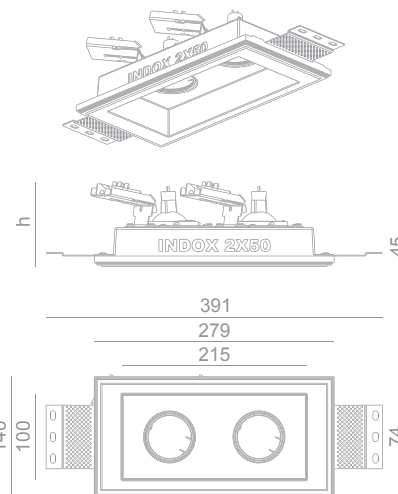

Included: installation system for gypsum ceiling 9 - 12 - 15 mm

OPTIONAL INSTALLATION KIT

- REF N° 229 99 025 installation system for gypsum ceiling 25 mm
- REF N° 229 99 030 installation system for gypsum ceiling 30 mm
- REF N° 200 50 000 clip on lampholder ring, without diffuser
- REF N° 200 50 001 clip on lampholder ring - with frosted diffuser
- REF N° 829 00 000 Concrete box Indox 2x50 - Galvanized steel

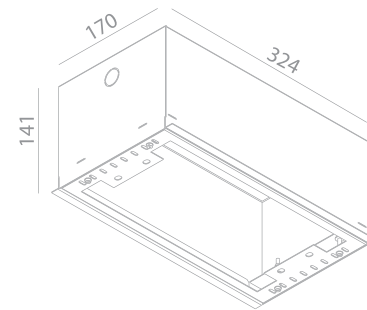

INDOX 2X50 LED 700LM CRI 80 FIX IP54

REF N° 229 72 041 BATHROOM phase DIM 2700K
 REF N° 229 72 141 BATHROOM phase DIM 3000K
 REF N° 229 72 045 OUTDOOR phase DIM 2700K
 REF N° 229 72 145 OUTDOOR phase DIM 3000K

2xXicato LED - 2x8,3 W - 2x720lm @ 70°C
 ☐ - 230V/50Hz - inclusive LED driver
 36° - ▽ - (0.5m) - ⚡ CE - 850°C - 2 SDCM
 Outdoor: Waterproof Calcyt+®
 h=122 - (144x283 mm)

INDOX 2X50 LED 500LM CRI 97 FIX IP54

REF N° 229 72 941 BATHROOM phase DIM 2700K
 REF N° 229 72 841 BATHROOM phase DIM 3000K
 REF N° 229 72 945 OUTDOOR phase DIM 2700K
 REF N° 229 72 845 OUTDOOR phase DIM 3000K

2xXicato LED - 2x8,5 W - 2x500lm @ 70°C
 ☐ - 230V/50Hz - inclusive LED driver
 36° - ▽ - (0.5m) - ⚡ CE - 850°C - 2 SDCM
 Outdoor: Waterproof Calcyt+®
 h=122 - (144x283 mm)

INDOX 2X50 HAL

REF N° 229 10 050 Adj. ⚡ IP20
 REF N° 229 10 051 Fix. IP54 BATHROOM
 REF N° 229 10 055 Fix. IP54 OUTDOOR

⚡ 2x QR-CBC 51 - 50W - Gx5.3 - 12V - ⚡
 CE exd lamp and transfo - ▽ - (0.5m) - 850°C
 Outdoor: Waterproof Calcyt+®
 ⚡ - h=98 - (144x283 mm)

INDOX 2X50 ES

REF N° 229 11 050 Adj. ⚡ IP20
 REF N° 229 11 051 Fix. IP54 BATHROOM
 REF N° 229 11 055 Fix. IP54 OUTDOOR

⚡ 2x QPAR 16 - 50W - GZ10/GU10 - ⚡
 CE 230V/50Hz - exd. lamp - ▽ - (0.5m) - 850°C
 Outdoor: Waterproof Calcyt+®
 ⚡ - h=100 - (144x283 mm)